

沈阳瑞思达轴承有限公司

SHENYANG TOTAL BEARING CO., LTD.

Tel: 024 22945833 22923833 24853899

Fax: 024 88729249

Mobile: 13940483518 15640413155 (微信)

Web: <https://www.rstbearing.com.cn>



FAG



**added
competence**

Bearing Solutions for Machine Tools

SCHAEFFLER GROUP
INDUSTRIAL

added
competence

“Added Competence” for Your Success

With their trend-setting bearing solutions for ball screw supports, main spindles, rotary tables and linear guidance systems, INA and FAG have been leaders on the global market for decades. However, in most cases, the bearing components alone are not the decisive factors for these machine subsystems.

Our customers still benefit from a significant increase in efficiency and unique selling points for our “ready-to-mount” products. After all, these compact bearings are put into operation with this basic principle in mind: unpack it, bolt it on, and it’s ready to use. Also, the integration of important functions such as measuring, sealing, lubrication, braking, and so on in the components themselves becomes increasingly important alongside the bearing supports for optimizing the entire machine tool system. This approach lives up to our new strategy for production machinery called “added competence,” since it centers on the idea of system solutions for the bearing, bearing support position and the complete system. This means that you now have access to a range of products that covers all your machine tool applications.

We have added another exceptional partner to our group of companies – IDAM (INA Drives & Mechatronics), since direct drives and mechatronic solutions are increasingly put into operation in machine tools. This means that with the bearing components and the right drives, we supply complete systems from a single source to meet all your requirements.

This opens up a wealth of new technical and commercial design scopes for your applications as well as considerable advantages regarding time and process chains.

As far as products are concerned, we offer a comprehensive, well-balanced range, precision technology and the highest quality. A global network of engineers, service technicians and sales technicians is available in order to keep up with the pace of your developments, thereby ensuring constant communication between you and us.

We always have the right product for your application. Just ask us about it.

沈阳瑞思达轴承有限公司

SHENYANG TOTAL BEARING CO., LTD.

Tel: 024 22945833 22923833 24853899

Fax: 024 88729249

Mobile: 13940483518 15640413155 (微信)

Web: <https://www.rstbearing.com.cn>



The Right Product for any Application

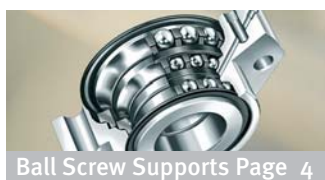

Ball Screw Supports Page 4

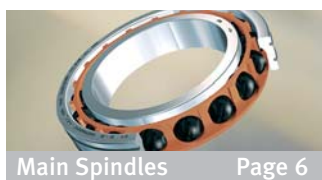

Main Spindles Page 6

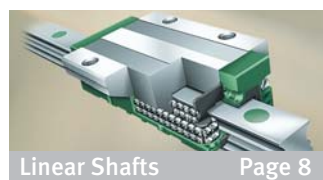

Linear Shafts Page 8



Direct Drives Page 10



Rotary Tables Page 12

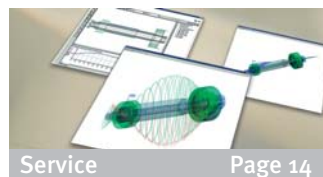

Service Page 14

Only the right bearing support makes the sequence of movements in machine tools perfect. INA and FAG have been working for decades with machine and equipment manufacturers from a wide range of sectors. Numerous new product developments are the result of these productive partnerships. We produce customized application solutions that make machines faster, safer and more precise – in short – more economical.

On the following pages we will show you how we make this possible. If you'd like more information, please visit our website:

www.machinetool.ina.com

沈阳瑞思达轴承有限公司

SHENYANG TOTAL BEARING CO., LTD.

Tel: 024 22945833 22923833 24853899

Fax: 024 88729249

Mobile: 13940483518 15640413155 (微信)

Web: <https://www.rstbearing.com.cn>



Ready-to-Mount Bearing Supports



INA Ball screw support bearing unit for screw drive nuts

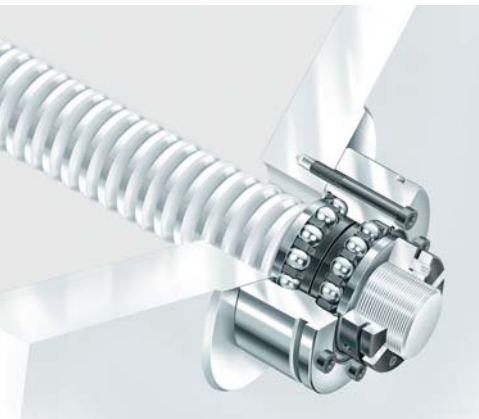

A face milled surface on the adjacent structure is all that is required with INA ball screw support units. The bearing housing bore does not need to be machined. The bearing unit centers itself during installation by moving the screw drive nut

Electromechanical drive systems for machine axes can be put into operation easily and economically with maintenance-free ball screw supports made by INA and FAG. Our product range originates from a deep understanding of systems and an attention to detail, which, due to our ready-to-mount products, leads to verifiable simplification and savings in the entire machine tool system.

Maintenance-free thrust angular contact ball bearing units that can be bolted on are particularly efficient in reducing system costs. INA series ZKLN and ZKLF are the classics of our range that ensure reliable bearing supports for ball screw shafts in small spaces without the need for complex adjacent structures.

With their high connection accuracy and rigidity, low friction and high torsional strength, these thrust angular contact ball bearings are in great demand all over the world. The seals have already been integrated.

The ZKLF series is available as a matched pair bearing (four rows) for extreme loads at high speeds. Bearings especially designed for power screw drive nuts are also available.

DKLFA bearings have been specially developed for locating-locating screw drives. They are the ideal solution in so-called “extended” ball screw supports that are axially preloaded to compensate thermal expansion. A third row of balls supports the permanently increasing

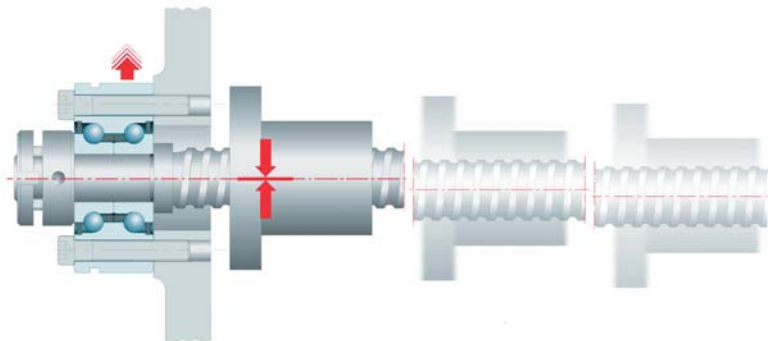

Alignment of the bearing by moving the screw drive nut

沈阳瑞思达轴承有限公司

SHENYANG TOTAL BEARING CO., LTD.

Tel: 024 22945833 22923833 24853899

Fax: 024 88729249

Mobile: 13940483518 15640413155 (微信)

Web: <https://www.rstbearing.com.cn>

axial load on one side that is caused by the stretching forces. In addition, DKLFA bearings are extremely well suited for vertical shafts in machine tools under heavy loads. The outer ring leveled on both sides facilitates designs with extremely low section heights. These are also ready-to-mount.

The range is rounded off by FAG's single-row 7602, 7603 and BSB universal bearings. They can be used in any combination for specific operating conditions.

You can find detailed product information about ball screw supports in INA Publication TPI 123.

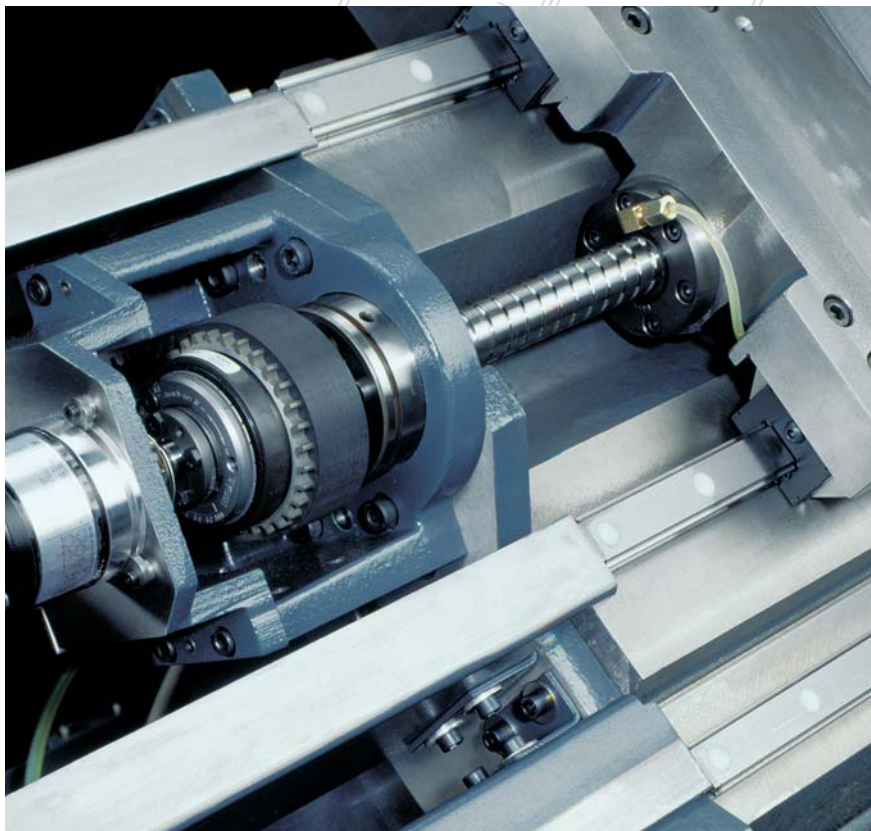

State-of-the-art ball screw support arrangement

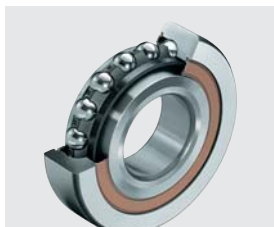

FAG BSB..-2z-SU



INA ZKLN...-2RS



INA ZKLF...-2RS



INA DKLFA...-2RS

Innovations Become Standards



Precise workpieces through innovative bearing solutions

For years now, FAG spindle bearings have been setting standards when it comes to reliability, precision and very high speeds. Innovative products such as hybrid designs, sealed bearings, FD non-locating ball bearings and X-life ultra premium bearings have played an important role in increasing the efficiency of spindles and machine tools. Today, they reflect the industry's standards. Extensive application

experience, close development partnerships with leading spindle manufacturers and consistent know-how transfer from FAG's aviation and aerospace technology have all contributed to this success story.

The generation of low temperature spindle bearings has recently started setting new milestones as a result of their optimized cage design compared to previous spindle bearings. The new design allows operation at up to 10% lower temperatures. Users can opt to increase speed limits by up to 10%. Practical applications of these bearings have been so successful that the cage design has been made the new standard design for all FAG spindle bearings. Spindle bearings are available as open or sealed bearings and as bearings lubricated for life as well as in a direct lube design for oil-air lubrication.

For non-locating bearing positions, FAG offers customers a sophisticated range

of high-precision cylindrical roller bearings that are available in both a double-row and a hybrid design. These bearings are characterized by their capability to support high loads, their high rigidity and excellent accuracy.

Special non-locating ball bearings have been designed for motor spindles. These floating displacement bearings (FD..) consist of an outer ring with a deep-groove ball bearing design, of ceramic balls and a cylindrical inner ring made from Cronidur high performance steel. They are available as both sealed non-locating bearing solutions lubricated for life and as versions designed for oil-air lubrication. The non-locating ball bearings ensure that the outer ring can be displaced without affecting the inner ring. They achieve operating side speeds for the first time.

Our new spring-loaded and ready-to-mount components provide a safe system solution for the non-locating



Hybrid bearings for very high spindle speeds: top products in machine tools



Sealed TX spindle bearings – fast, cool and lubricated for life



Direct lube spindle bearings for oil-air lubrication – for very high speeds



bearing position. They are compact bearing units with an integrated close sliding fit function. Spindle manufacturers benefit from using such a system solution because they can eliminate four components that are time consuming to mount. The bearing consists of a double-wide, specially coated outer ring with integrated spring supports and additional standard components of an FAG spindle bearing. Preload is adjustable. These units can be expanded to include additional functions such as seals, oil-air lubrication options, locking units and more to optimize them for specific applications. They significantly reduce the risks associated with non-locating bearing positions and offer very high accuracy. In addition, they minimize the time required for mounting as well as system costs.

For detailed product information, please refer to our FAG catalog AC 41 130/6.



For extremely fast and high performance machine tools: FAG spindle bearings set standards



Spring preloaded non-locating bearing unit – ready-to-mount system solution



Floating displacement bearings – high-speed non-locating ball bearings



High-precision cylindrical roller bearings – very rigid, large load-supporting c



Reliability and Dynamics



Profiled rail linear guides

... with rollers

INA RUE roller-type profiled rail linear guide systems have been working reliably for many years in many production machines. However, manufacturers and design engineers always want more.

More load carrying capacity, more dynamics, more long-term precision, more machine availability...For us, this can only mean more X-life, since only products whose parameters clearly exceed the norm receive the X-life mark of quality.

X-life profiled rail linear guides advance into a new performance class. With a running speed that is 40% higher with unchanged load carrying capacity and rigidity, they are ideal for highly-dynamic machine tools.

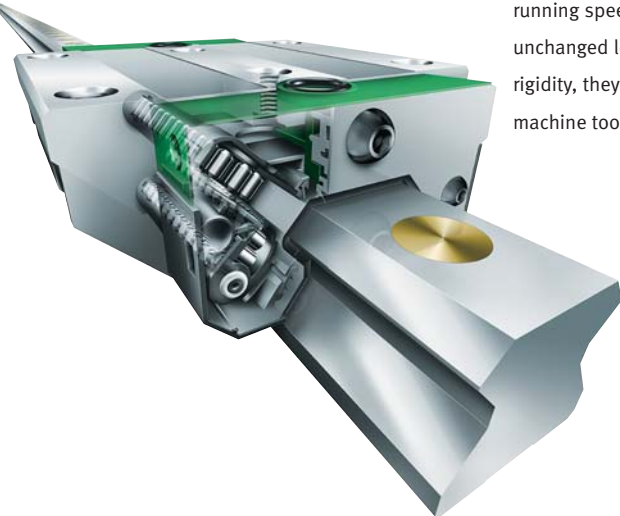

“Heavy-duty sprinter”: 40 % higher running speed, robust due to fewer components and available with optional roller chain – all in the same mounting space!



... and with balls

Our customers increasingly request reductions in noise emissions. We meet these demands with our “quietest” product, our four-row ball-type profiled rail system KUVE..B KT in X-life-quality. It is based on a new rolling element separation principle – the quad spacer. This means that the collision noises in the system are reduced, noise is lowered to a minimum, and the high dynamics required by the adjacent structures remains high.

... and the appropriate accessories

The unrivaled range of accessories for INA profiled rail linear guides contains everything you need: damping carriages, seals, equipment for long-term and minimal-quantity lubrication, braking and clamping elements, etc.

Just ask us!



Our compact model: four-row ball type profiled rail units combine high load carrying capacity and rigidity with high dynamics. An X-life product from INA Linear Technology

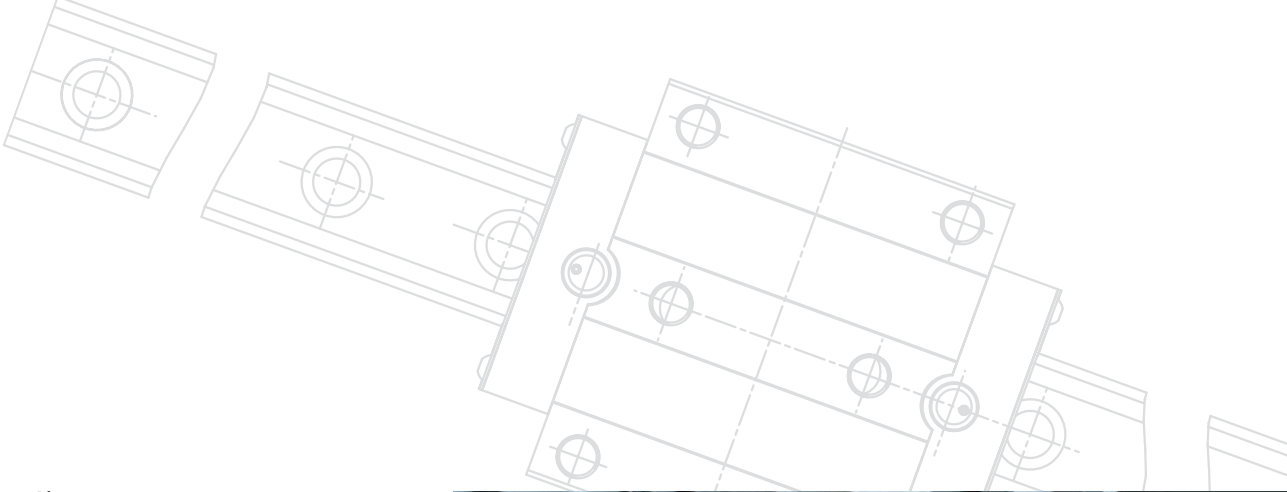

Linear actuators

Feed and discharge systems, tool changers and handling systems are some of the preferred applications for INA's ready-to-mount linear actuators. Our MKUVS 42 LM, a linear actuator with a direct drive, is a new addition to the range. It is especially suitable for fast positioning movements in machine tools and can also be used as a tool changer. They are compact and therefore require less space due to their integrative design. As a systems supplier, we also offer customized components for our customers, such as motors, gears, control systems, and so on.

INA's Linear Technology Department has a complete range of products to provide more power for your machines – for everything that moves, from the main shaft to the adjacent structures. For more information, send an email to this address: info.linear@de.ina.com

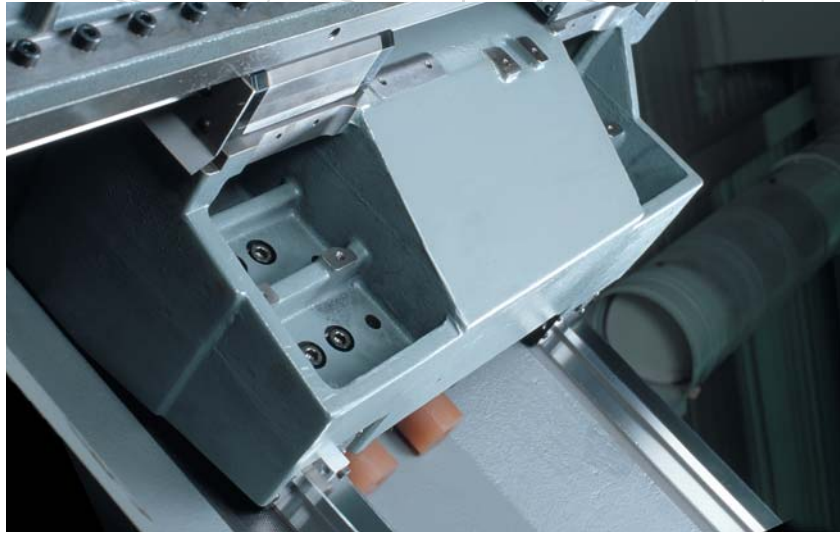

RUE...E roller type profiled rail units provide reliable support for the main axes of machine tools

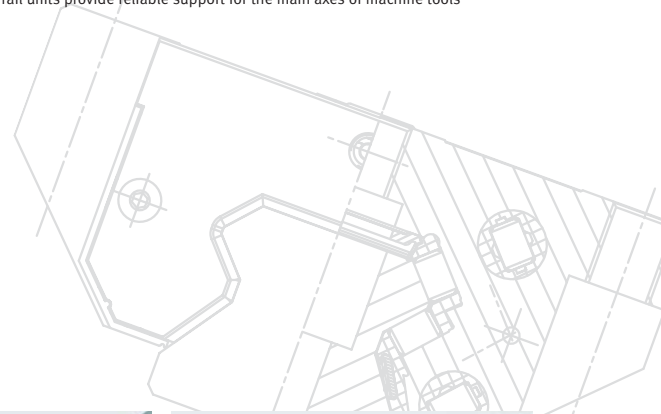

"Minimax principle": durable KS shaft guidance systems with an unbeatable price-performance ratio

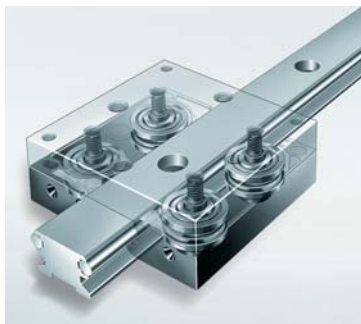

Quiet and smooth: LFL..B track roller linear guide for door opening systems that are easy to operate



Powerful, fast and durable: Extremely high loads can be transported vertically with the MLFI tandem module

The Perfect Drive for any Application

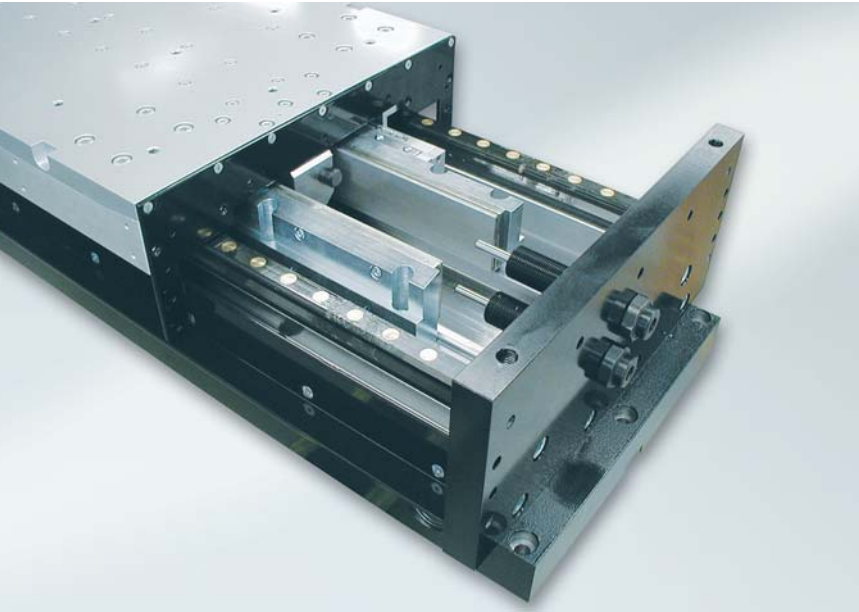

Precision linear tables for milling and grinding machines with L2D motor

They produce enormous power density in the smallest of mounting spaces. These are just some of the advantages of these virtually wear-free drives:

- High rotational and linear speed variance
- Excellent dynamics and rigidity
- High final speeds
- High acceleration and braking capabilities
- High positioning and repeat accuracy

IDAM offers customized engineering solutions with linear and rotary drive systems in combination with INA/FAG guide assemblies and bearing assemblies and our own sensors.

INA Drives & Mechatronics (IDAM) develops and manufactures linear and rotary AC synchronous motors that are increasingly replacing conventional drive technology. IDAM direct drives are at the forefront of modern technology and offer the perfect solution for every application.

Linear drives

Riveted synchronous L1, L2 and L2D series motors are especially suitable for machine tools.

L1 motors operate accurately and efficiently with low heat generation and



Linear synchronous motor: Type L1



Linear synchronous motor: Type L2

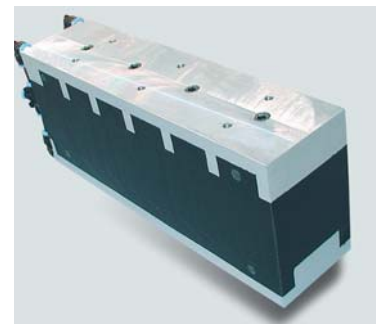

Linear synchronous motor: Type L2D



the power generation is approximately 6-8 N/cm². These linear drives are particularly suitable for measuring and feed tasks due to their slim design.

With the L2 motor series, our developers have succeeded in combining high power generation (> 10 N/cm²) with excellent synchronization properties and considerable efficiency – precisely the characteristics required in the precision machine industry. The cogging and load pulse forces have also been practically eliminated. This results in optimum synchronization, one of the prerequisites for precision processing. The high winding density means that heat penetration into the surrounding machine frame is minimized. Two separate cooling circuits and heat insulation also further reduce heat penetration.

The L2D series is characterized by an excellent power to volume ratio and by the lack of attraction to the guide system. This means it is predestined for

dynamic applications requiring high performance. A very compact design supports the integration of these motors in the mounting structure.

Rotary drives

Slotted high-torque synchronous motors designed as internal and external rotors are characterized by efficient power generation, maximum power density, high acceleration capability and high speeds. These brushless power packs operate without wear and friction.

Our high-speed series HSR and HSRV achieve even more, with more output and higher circumferential velocity due to their innovative winding structures. The circumferential velocity of these customized motors can reach up to 50 meters per second - the speed of an express train, with a mechanical release output of up to approximately 50 kW.

System solutions

INA, FAG and IDAM can provide customized system solutions for all motor series, since we have our own resources. These include motor, bearing supports/guidance, interface components, measuring systems and sensors.



Rotary synchronous motor: Type RI

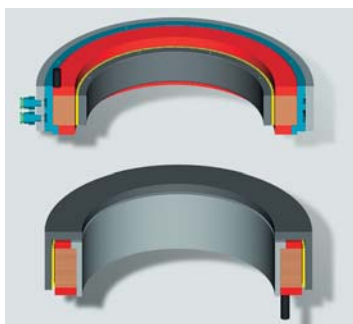

Rotary synchronous motor: internal and external rotors



INA/FAG Bearing Supports – First Place Worldwide



Precision rotary / tilting tables achieve maximum performance thanks to bearing solutions supplied by INA and FAG

Bearing supports for rotary tables in production machines are one of Schaeffler Group Industrial's most sophisticated areas of expertise.

Our product range of low-maintenance INA combination thrust and radial bearings and angular contact thrust ball bearings as well as thrust needle roller cage assemblies and thrust washers is the most comprehensive range for production machinery worldwide. Be it rotary tables, faceplates, milling heads or measuring and inspection equipment – our engineers can provide you with efficient solutions that meet all technical requirements.

Our optimized combination thrust and radial cylindrical roller bearing, series YRTS, features limiting speeds that are seven times higher than previous design standards as well as extremely low and consistent friction torque profiles while also increasing tilting rigidity.

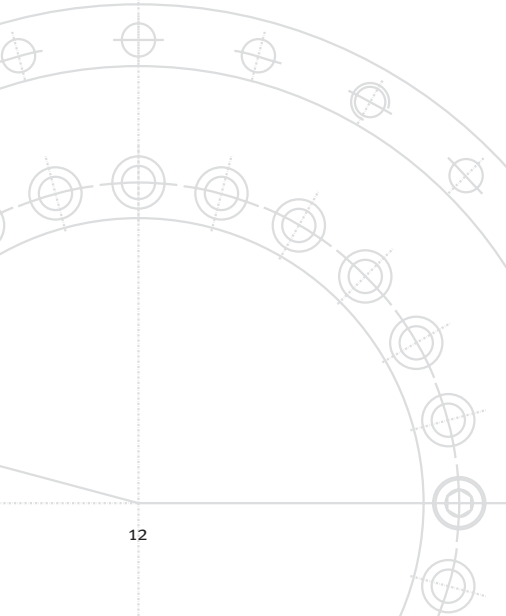

FAG RTC..



INA YRT..

Reduced friction results in consistently low bearing temperatures which in turn has a positive effect on the precision of the entire machine assembly.

This is why YRTS bearings are an ideal complement for highly dynamic acceleration in direct-drive rotary tables that allow the performance potential of direct drives to be fully utilized. Equipping these bearings with a rotary encoder system SRM is optional (YTRSM).

Electronic measuring equipment and IDAM direct drives work together extremely well. The anti-vibratory connection of system components to the surrounding structure minimizes vibrations resulting from machining. The measuring system has been integrated in the design space of the bearing to prevent additional time spent on mounting.

Very high speeds, high axial and radial load capacity and long operating times – this is when you need angular contact

thrust ball bearings, series ZKLDF. These angular contact thrust ball bearings with a 60° contact angle and are available as low-friction, ready-to-mount and greased bearing units. They provide reliability and precision when moving combined loads.

Potential applications such as rotary tables, faceplates and milling heads that require runout accuracy are covered by our RTC series.

INA's YRT series occupies first place worldwide for standard applications.

Proven reliability, precision, efficiency and consistent development have ensured our success.

All rotary table bearings have been dimensioned in a way that allows them to be interchangeable, increasing design flexibility for machine tools.

For compact designs with limited design space, we supply our AXK series thrust needle roller cage assemblies.

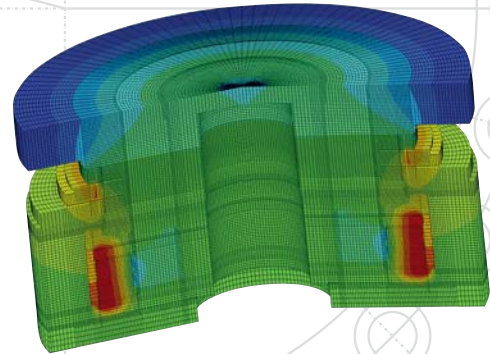

Positive effects on machine precision due to low bearing temperatures

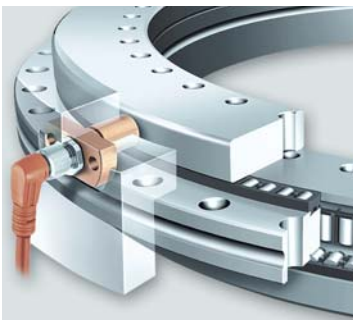

INA YRTS(M)..



INA ZKLDF..



INA AXK../ASS..

Market Leader in Bearing Design

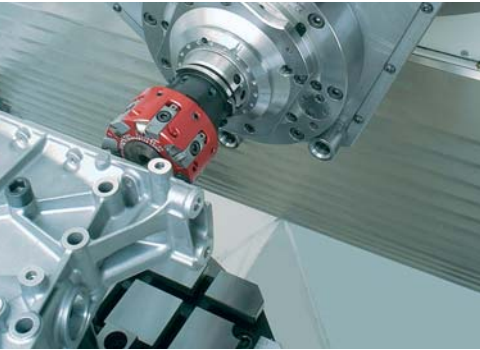

Increased operating safety – shorter development times. We create models of real-life operating conditions when we design our bearings

With its BEARINX® software, INA has created one of the leading programs for making rolling bearing calculations. The software allows detailed rolling bearing analyses – from individual bearings all the way down to complex shaft systems.

Over the past few years, FAG's rolling bearing calculation know-how has been successively integrated. Now the current version has been upgraded again by including a special module for spindle calculations.

The range of BEARINX® functions has been extended to include the impact of centrifugal forces on load distribution and the running behavior of rolling elements in ball bearings.

BEARINX® online spindle calculations lets customers determine real spindle bearing loads and offers the following options:

- Recommendations for mounting fit based on specified speeds

- Calculation of design parameters for contact pressure and kinematics in the bearing
- Kinematic bearing frequencies for vibration analyses
- Calculation of bearing supports rigidity at the operating point while accounting for all relevant influences
- Graphic shaft reactions such as shaft deflection and shaft inclination
- Critical speeds and graphic representation of eigenforms
- Calculation of fatigue life to DIN ISO 281

The program includes many more useful components that allow users to select the appropriate bearing solution quickly and safely.

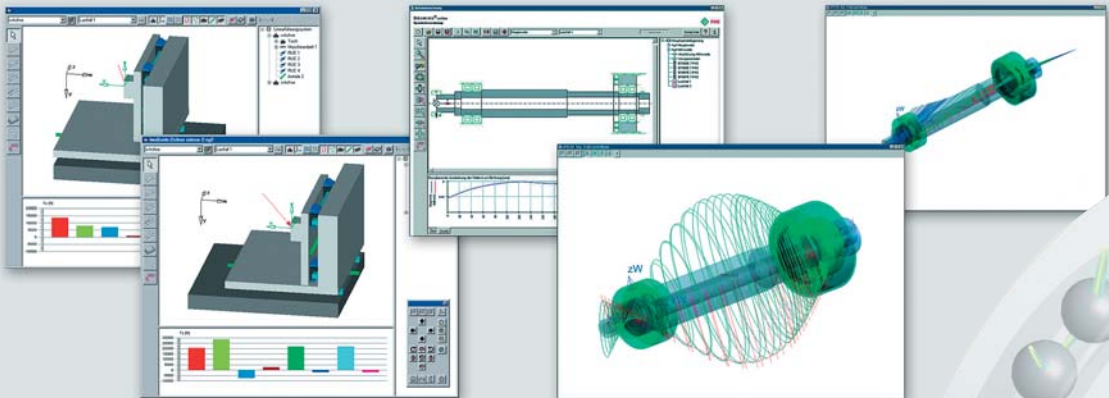



Reliable Productivity, Improved Machine Capability

As your development partner, we provide you with practical, efficient products and the professional design of bearing positions in machine tools. But our services include much more, such as machine evaluations in terms of dynamics, geometry, noise, etc. (modal analysis).

Our subsidiary FAG Industrial Services GmbH (FIS) complements this range in an ideal way, offering services, tools and lubricants for machine operation and maintenance.

The offline and online monitoring of main spindles is of particular interest for the machine tool industry. Performing frequency-selective analyses of vibration patterns can provide early indications of changes in spindle conditions.

In addition, we offer comprehensive mounting services. You can request our technicians to provide support on site for large machines.

FAG offers periodical classroom instruction and practical training on spindle bearings that are held at either our training center or at the customer's location on request.

Schaeffler Group Industrial can offer a well-balanced product range – from individual components to customized bearing support systems.

Our application engineering and technical services departments work together to provide customers with efficient solutions that meet all technical requirements – as a complete package from a single source!

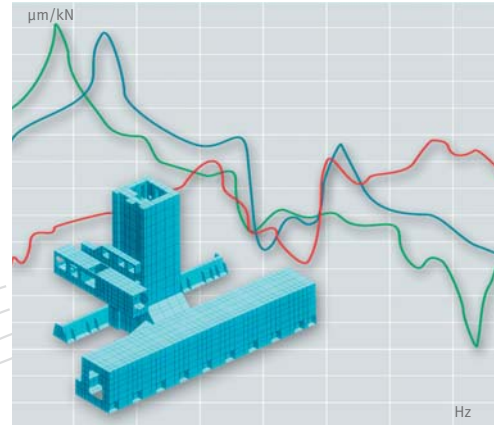

Modal analysis



Spindle monitoring



沈阳瑞思达轴承有限公司

SHENYANG TOTAL BEARING CO., LTD.

Tel: 024 22945833 22923833 24853899

Fax: 024 88729249

Mobile: 13940483518 15640413155 (微信)

Web: <https://www.rstbearing.com.cn>



INA-Schaeffler KG

Industriestrasse 1-3
91074 Herzogenaurach (Germany)
Internet www.ina.com
E-Mail Info@de.ina.com

In Germany:

Phone 0180 5003872

Fax 0180 5003873

From other countries:

Phone +49 9132 82-0

Fax +49 9132 82-4950

FAG Kugelfischer AG & Co. oHG

Georg-Schäfer-Strasse 30
97421 Schweinfurt (Germany)
Internet www.fag.de
E-Mail FAGdirect@de.fag.com

In Germany:

Phone 0180 5003872

Fax 0180 5003873

From other countries:

Phone +49 9721 91-0

Fax +49 9721 91-3435

Every care has been taken to ensure the correctness of the information contained in this publication but no liability can be accepted for any errors or omissions. We reserve the right to make changes in the interest of technical progress.

© by INA/FAG · 2005, September

This publication or parts thereof may not be reproduced without our permission.